

APPENDIX C

017 TIMING EXAMPLES

C.1 TIMING DIAGRAMS

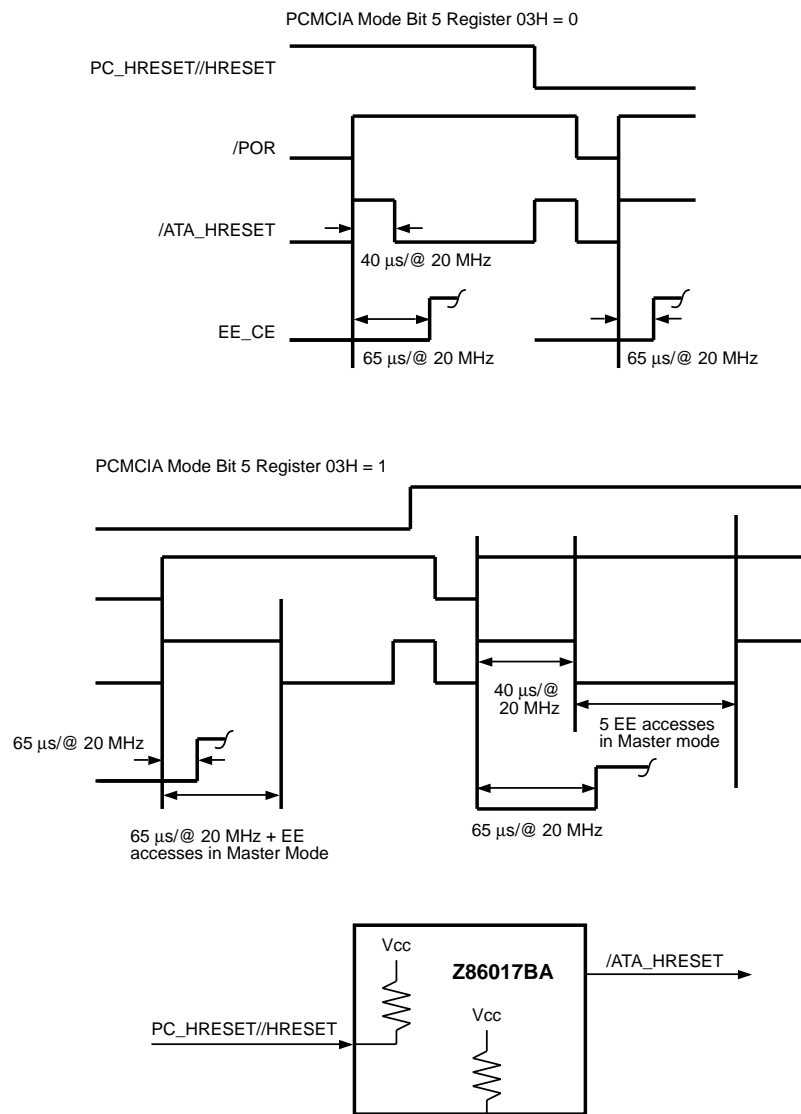

Figure C-1. Z16017BA Reset Timing PCMCIA Mode

C.1 TIMING DIAGRAMS (Continued)

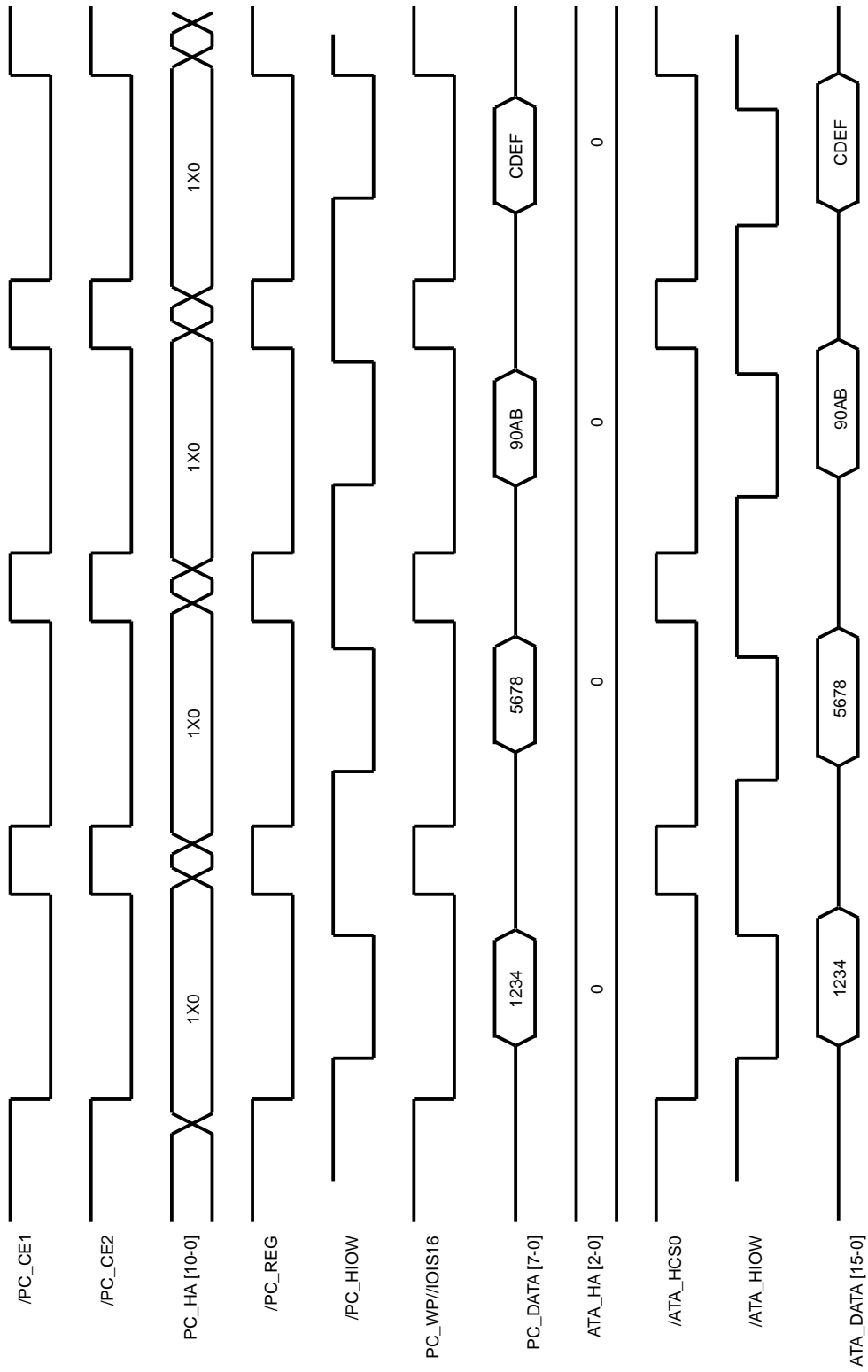

Figure C-2. PCMCIA ATA/IDE 16-Bit I/O Write
 (Register 24 = 01, Internal IOIS 16 is selected)

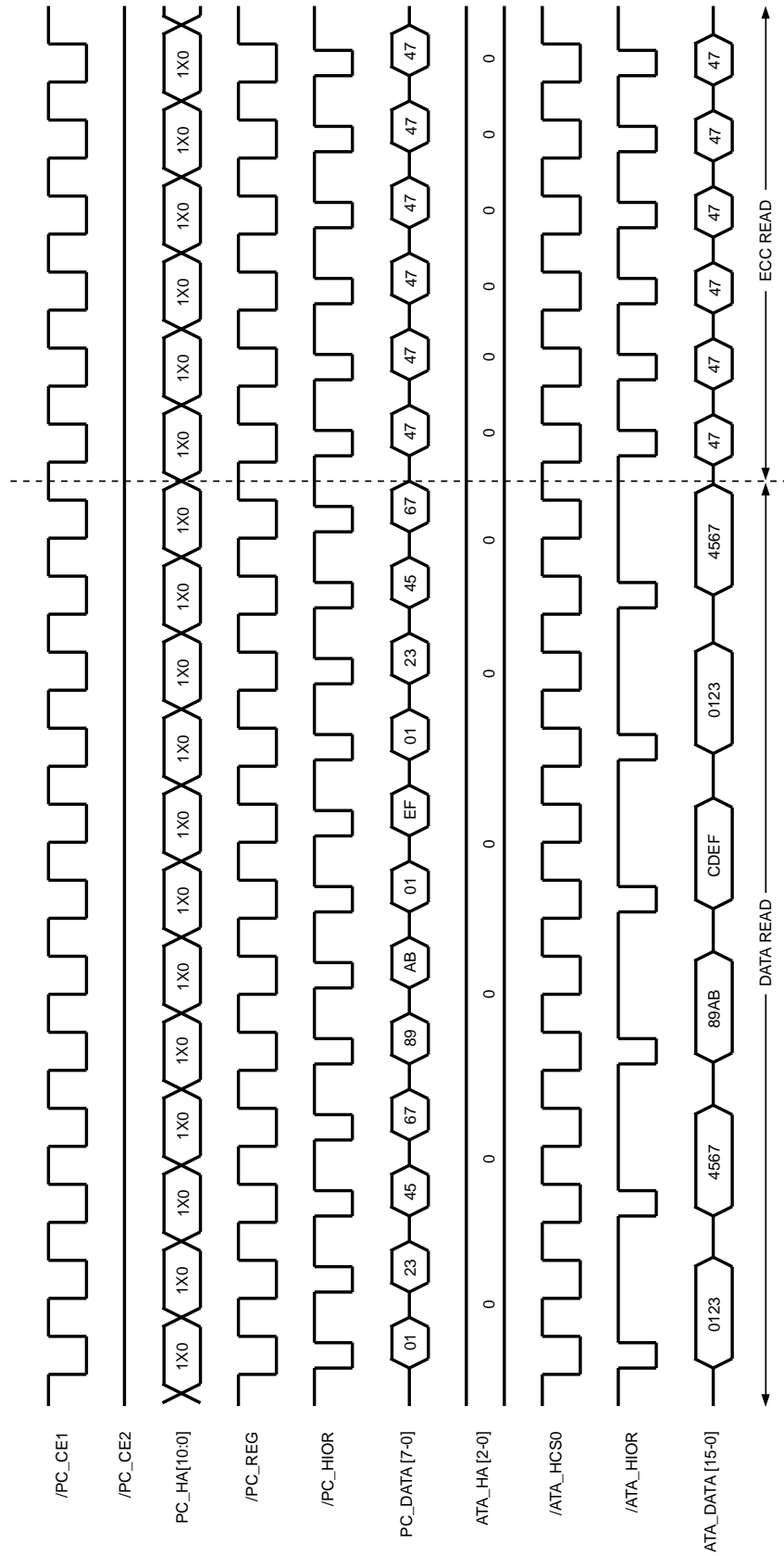

Figure C-3. PCMCIA ATA / IDE 8-Blit Long Read
(Reading 512-byte data plus 6-byte ECC)

