

DESIGNING A LOW-COST THERMAL PRINTER

USING THE Z86E21 TO CONTROL THE OPERATING CURRENT ON LOW-COST THERMAL PRINTERS PROVIDES DESIGN FLEXIBILITY AND HELPS SAFEGUARD PERFORMANCE.

INTRODUCTION

Compact and low-cost thermal printers are popular for many applications: point of sale equipment; medical and industrial instrumentation; micro-fax and micro-printers for the consumer markets, as well as other applications. Each application is unique with different operating environments and performance requirements. In this application example, the Z86E21 is used as a common controller for thermal

printers. The hardware and software flexibility and performance potential of the Z86E21 make it ideal for this type of application. This Application Note provides design engineers with information on how the Z86E21 interfaces with thermal printers, creating a platform from which they can customize their designs.

Mechanical Considerations

Thermal printers have several common, yet important attributes. Most important is a thermal print head which has a number of resistive heating elements. When heated, these elements produce an image on heat sensitive paper. Secondly, thermal printers must advance the print head across the paper media. It must make provisions to advance the paper after the head has traversed the width of the paper. Depending upon the cost and complexity of the thermal printer used, the mechanism for paper advance can be an independent motor and gear drive assembly, or simply a ratchet driven line feed for every print head carriage return.

Additionally, there are mechanical features which enable interconnect to the controller circuit. Also, there are provisions for securing the assembly to a case and paper cutter. The printer must supply sufficient pressure on the paper, sandwiched between the platen and roller, as well as maintain pressure when the paper is torn across a fixed, serrated cutter bar. Figure 1 shows a typical thermal printer. Note the threaded, head feed screw attached via a gear system to stepper motor #1. Motor #2 advances the paper as required by rotating the platen through a gear drive.

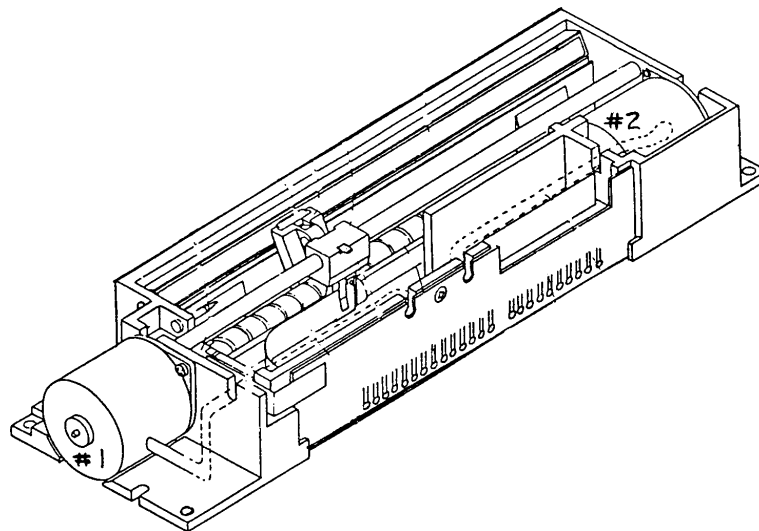

Figure 1. Thermal Printer

Electrical Considerations

The key elements to controlling thermal printers are in properly synchronizing the movement of the print head and paper to the required application. Also, as in any closed loop control system, the printer must deliver a status signal back to the controller. Since paper movement is continuous, it has no electronic analog of "begin and end", except for "paper out" or "paper jammed" conditions. To close the loop, thermal printers define a position for the print head as "home", and give an active Low feedback status when "home." Normally, this is at the far left of the carriage span.

Four-phase stepper motors are commonly used to transport the print head. If the printer is to print bi-directionally, a second stepper motor is used for paper advance. The equivalent circuit for the four-phase stepper motor, and the required support components are shown in Figure 2. The four diodes are used to discharge the inductive kick which is generated when the transistors are switched off. The Zener diode provides threshold for this action. Table 1

shows typical phase drive sequences for clockwise and counter clockwise rotational motion of a four-phase stepper motor (note equivalent Hex code values).

Table 1. Typical Phase Drive Sequences

Clockwise			Counter Clockwise		
Step	Phases	Hex Code	Step	Phases	Hex Code
1	1101	C	1	0011	3
2	0110	6	2	0110	6
3	0011	3	3	1100	C
4	1001	9	4	1001	9

Thermal print heads are arranged in a typical column of seven, eight, or nine elements. Each element is called a dot. Figure 3 shows the arrangement of an 8-dot head.

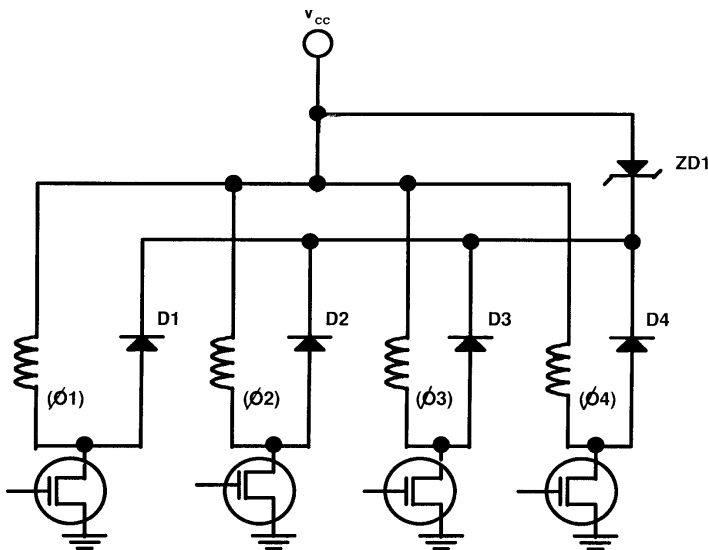

Figure 2. Equivalent Circuit for Four-Phase Stepper Motor

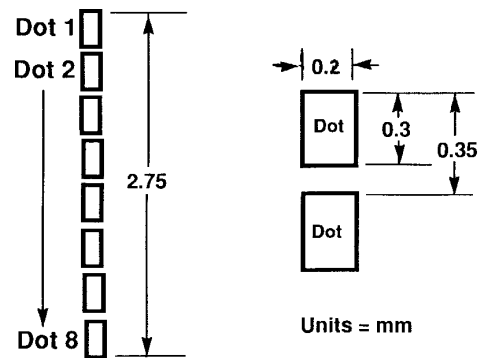

Figure 3. 8-Dot Head Arrangement

Since the print head traverses the width of the paper on the head feed screw, the electronic signals required to operate the head are delivered via a flexible printed circuit (typically copper traces sandwiched between mylar). Each dot has a closely controlled value of resistance. This resistance ranges between 14 and 18 Ohms in compact thermal printers. Heat is generated by a given dot through I^2R dissipation.

A dot has a maximum applied energy specification and a recommended or rated specification. Printer manufacturers describe this energy in joules, or more closely, milli-joules (mj). One joule per second is one watt. Energy is usually expressed with a time base. Understanding this concept is essential in thermal printer design. The print circuit must not exceed the energy rating of a dot. Simultaneously, it must control the duration (dissipation) to ensure proper print quality and protection of the print head elements (dots).

For example, a dot has a resistance of 16 ohms, a rated energy spec of 2.10 mj, and a maximum energy spec of 2.52 mj, at 5 volts. The pulse width (time) required to apply the rated energy in milliseconds is given by the equation in Figure 4.

Figure 4. Thermal Energy Equation

$$t = R * E / V^2$$

Where: R = Head Resistance (Ohms)
E = Applied Energy (mj)
V = Voltage (Volts)
t = Pulse Width (ms)

The Thermal Energy Equation yields a required pulse width of 1.34 ms to apply the rated energy of the head. The value of E, the applied energy in the equation, needs to reflect the effects that ambient temperature fluctuations induce. The equation to compensate the applied energy used in deriving pulse width is given in Figure 5.

Figure 5. Ambient Temp Compensation Equation

$$E = E_0 (1 + T_0 - T/100)$$

Where: E = Applied Energy (mj)
E₀ = Rated Energy (mj)
T₀ = 24 °C
T = Ambient Temperature (°C)

As illustrated above in the Figure 5 equation, as ambient temperature decreases, supplied energy must be increased. Thus, the pulse width is increased to maintain print quality.

Z86E21 Controller Application

Ports 0 and 1 are used on the Z86E21. Low cost 18-pin, bipolar, octal peripheral array drivers (ULN2801A) are used to interface TTL logic signals from the Z86E21 to the printer (Figure 7). The outputs from the ULN2801A's are capable of sinking the 500 mA currents that the stepper motor windings source. Additionally, an active dot can typically source 300 to 400 mA of current. The equivalent circuit of the ULN2801A is shown in Figure 8. Note the inclusion of discharge diodes and the use of Zener diodes as discussed in the Electrical Considerations section (see Figure 2).

When the print head reaches the far left position of the carriage travel, it is in the home position. The home pin is actively Low when this status is present (Figure 7). The 0.1 μ f capacitor (C1) debounces the event. The 2.2K resistor provides an RC time constant and current limit. The 1K resistor is a pull-up for the Z86E21 input. In this example,

a home status produces a falling edge interrupt. The 5K port pull-ups provide sufficient bias current to the bipolar inverters of the ULN2801A's.

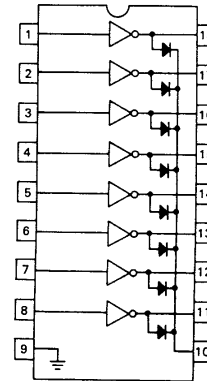

Figure 8. ULN2801A Equivalent Circuit

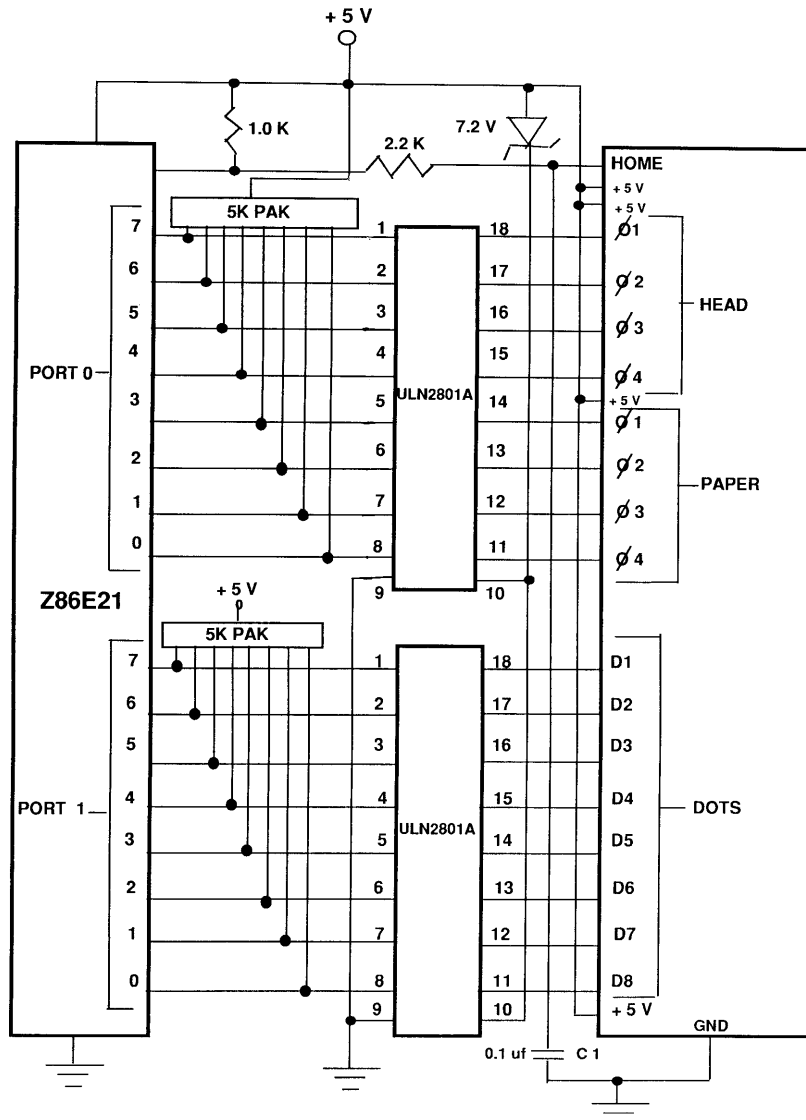

Figure 7. Z86E21 to 8-Dot Stepper Motor Control Interface

Print Head Protection

Depending upon the application environment and operating conditions, the designer must consider the degree of print head protection required. Bad resets, power fails, ESD jolts, and printing errors can potentially produce conditions whereby the head is left on too long. Depending on the maximum energy rating, the heads can be permanently damaged after only seconds of carrying current continuously. The designer should consider these various, potentially damaging, scenarios and plan to avoid or effectively manage them. One helpful design method is to install a MOSFET in the ULN2801A to V_{CC} path. An external watch-dog circuit could time the power-on duration in the print elements. In environments where ESD is a concern, the designer may consider using the Z86E40, a Z8 Family controller comparable to the Z86E21 but with the added feature of an on-chip watch-dog timer circuit. Multiple approaches to print head protection are worth the cost and effort.

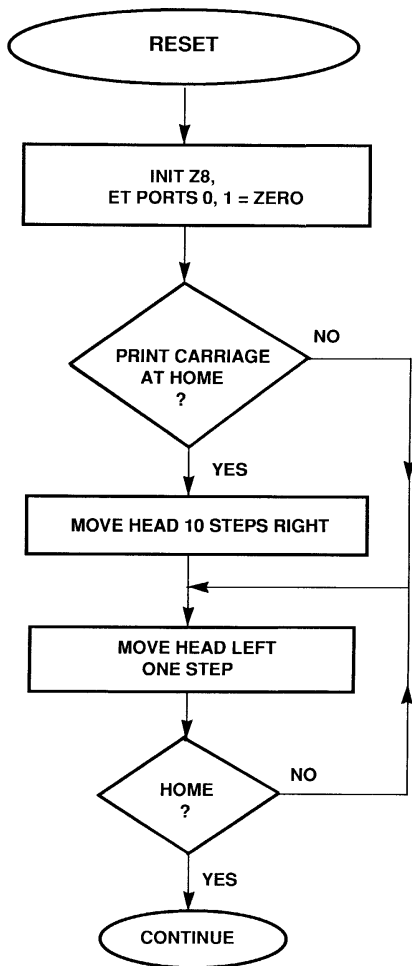

Figure 9a. Initialized Coding Flowchart

Initializing and Print Coding Flowcharts

The coding necessary to make this interface operate is shown in the Figure 9a flowchart. First, the Z86E21 is initialized and Ports 0 and 1 are set to zero. Counter/Timer 1 of the Z8 is used to provide a main task interrupt clock of 100 μ s. This task clock yields the millisecond order signals for incrementing stepper motors and activating thermal printer heads with the proper accuracy. Continuing the flow, the print head carriage is "homed." To do this, the home status is first polled for a Low. Then, actions are taken to move the head in order to generate a falling edge interrupt for IRQ2, Pin 32.

Once home status is secure, Figure 9b flowchart shows typical print coding flow. A character is available once it has reached an internal FIFO stack in the Z8 register file. This FIFO stack is maintained by the interrupts which handle the received characters on the serial or parallel interface. The ASCII character is then converted to an index address in the ROM where the bit map for that particular character is located. This bit map is then printed one column at a time, sequentially incrementing the head position one step.

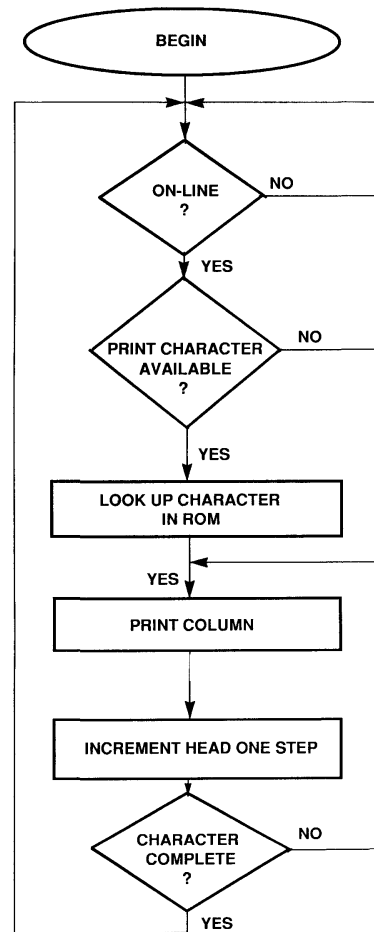

Figure 9b. Print Coding Flowchart

Z86E21 Flexibility

The Z86E21 further complements this application when considering the host interface possibilities available to the designer. The Z8 has UART on-board to easily implement an RS232-style serial interface to a host. Note that the Z8 is only required to receive data, thus Rx/D is the only active UART pin. Flow control comes from P31, where an active High condition flags printer not ready (Figure 10).

Another possible parallel interface is the Centronics. With 32 potential I/O signals on the Z8, 17 of which are used for

the printer interface, only a subset of the Centronics interface can be adapted directly to the Z8. The designer could adapt full interfaces if required by the application, through additional logic (Table 2).

The Z8 has two-wire handshake logic built-in, greatly simplifying data flow. The asterisks (*) in Table 2 show the boundary between a simple parallel interface, and a complex one.

Table 2. The Parallel Interface				
#	Name	Transmitter	Function	
1	/STB	Host	Active Low (/) indicates valid data Parallel data byte ↓ Active Low (/) indicates data received off line, error, or handling data	
2	D0	Host		
3	D1	Host		
4	D2	Host		
5	D3	Host		
6	D4	Host		
7	D5	Host		
8	D6	Host		
9	D7	Host		
10	/ACK	Printer	*****	
11	BSY	Printer		
12	PE	Printer		Printer out of paper
13	SLCT	Printer		Active high, printer is on, and selected
14	/ALF	Host		Auto Line Feed
15	/INT	Host		Reset
16	/ERR	Printer		General Machine Error
17	/SLN	Host		Select-in, from from host

Z86E21 Flexibility (Continued)

Figure 10 illustrates the parallel interface. Data lines are pulled up to improve drive characteristics on the bus. The /STB signal easily maps into the Z8 /DAV2 function, where a falling edge generates a service interrupt for the current valid data byte. The BSY strobe output from the Z8 closely matches the RDY2 function. Refer to the Z8 input handshake functions in the Z86E21 Product Specification for further details. The /ACK strobe can be implemented via software

in the character interrupt subroutine. Figure 11 shows the ideal handshake timing implemented by the software.

Conclusion

With a better understanding of how the Z86E21 interfaces with thermal printers, designers can take advantage of the flexibility and performance potential of this low cost Z8 microcontroller.

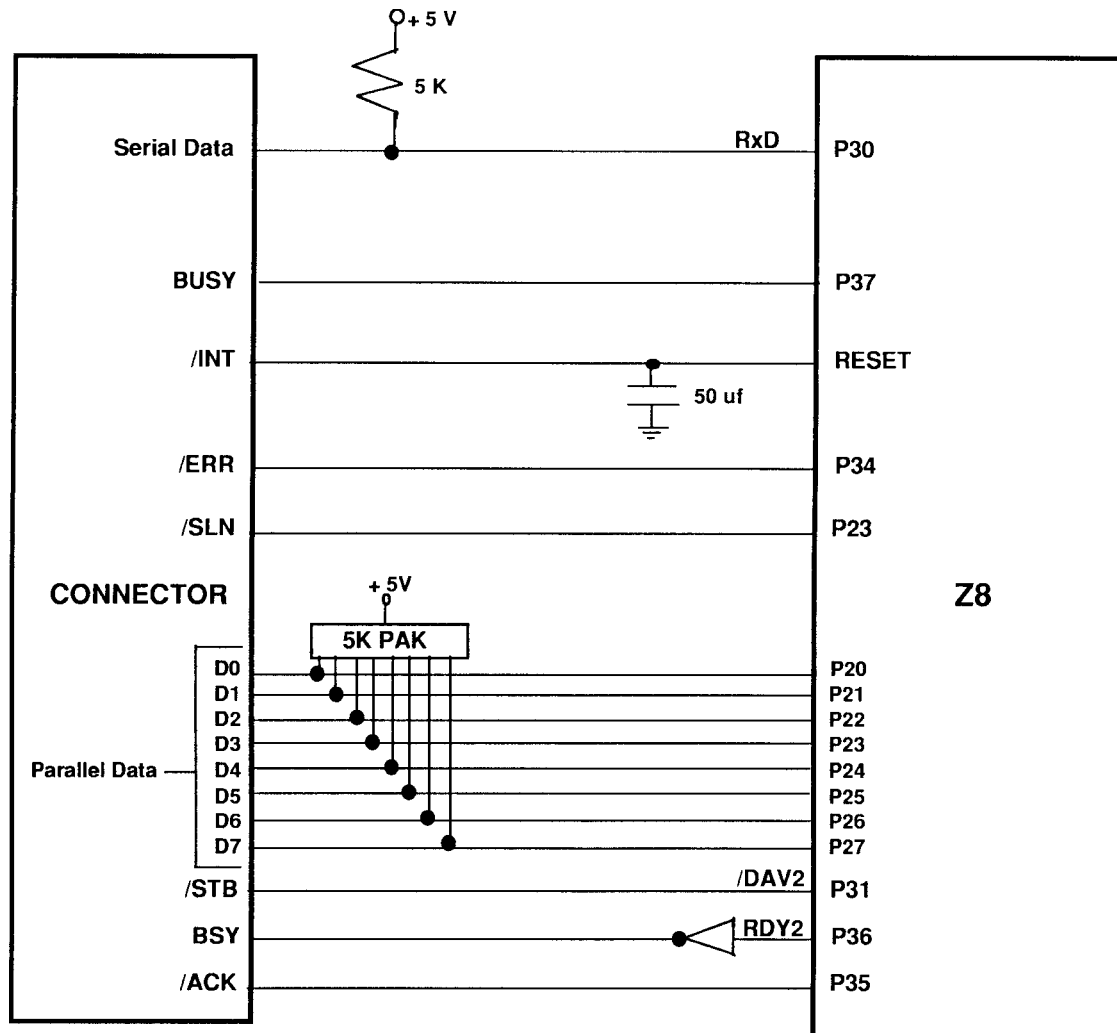

Figure 10. Z8 Implementation of a RS232 Interface

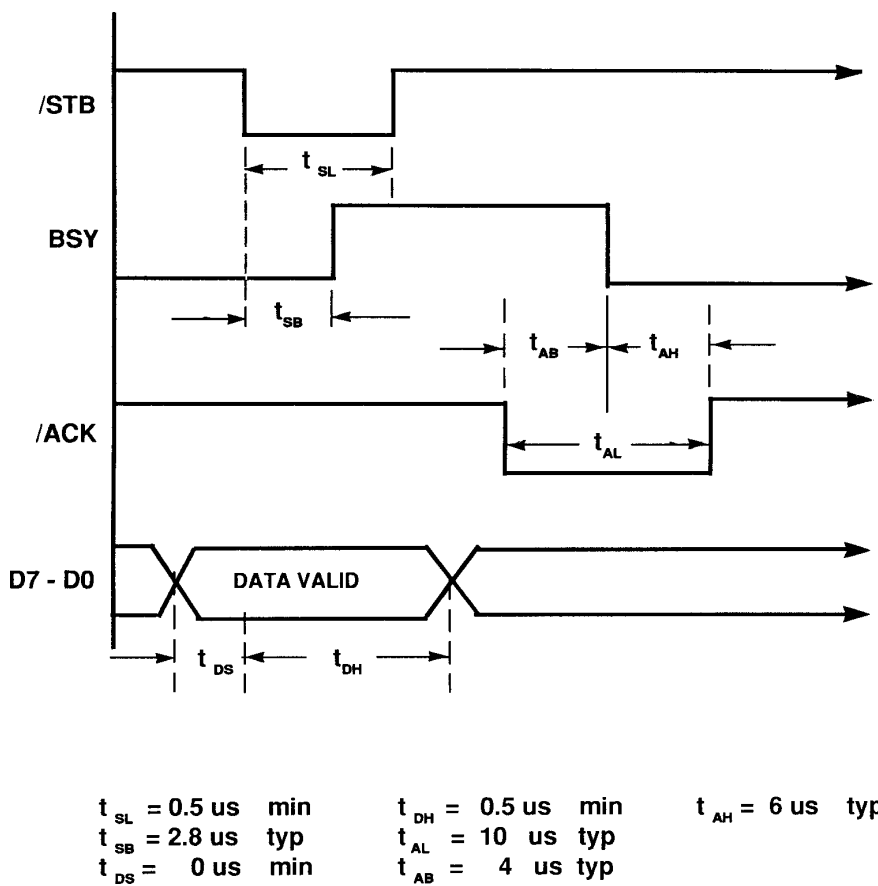

Figure 11. Parallel Handshake Timing

© 1997 by Zilog, Inc. All rights reserved. No part of this document may be copied or reproduced in any form or by any means without the prior written consent of Zilog, Inc. The information in this document is subject to change without notice. Devices sold by Zilog, Inc. are covered by warranty and patent indemnification provisions appearing in Zilog, Inc. Terms and Conditions of Sale only. Zilog, Inc. makes no warranty, express, statutory, implied or by description, regarding the information set forth herein or regarding the freedom of the described devices from intellectual property infringement. Zilog, Inc. makes no warranty of merchantability or fitness for any purpose. Zilog, Inc. shall not be responsible for any errors that may appear in this document. Zilog, Inc. makes no commitment to update or keep current the information contained in this document.

Zilog's products are not authorized for use as critical components in life support devices or systems unless a specific written agreement pertaining to such intended use is executed between the customer and Zilog prior to use. Life support devices or systems are those which are intended for surgical implantation into the body, or which sustains life whose failure to perform, when properly used in accordance with instructions for use provided in the labeling, can be reasonably expected to result in significant injury to the user.

Zilog, Inc. 210 East Hacienda Ave.
Campbell, CA 95008-6600
Telephone (408) 370-8000
Telex 910-338-7621
FAX 408 370-8056
Internet: <http://www.zilog.com>